

Intrinsically Safe Well Analysis Instruments

Jim McCoy and Bill Drake, Echometer Company
A. L. Podio, University of Texas at Austin

Abstract

Safety in the workplace is one of the major considerations for selecting and applying instruments for use in conjunction with oil and gas operations. All companies, government and labor organizations have developed guidelines and regulations aimed at making the workplace as safe as possible. In particular, instruments that are used in a hazardous environment have to meet strict requirements and specifications and be certified for use in explosive atmospheres. API has developed guidelines that define the level of hazard in relation to oil and gas production locations where explosive gases are present. It is important that the user of certified instruments understand the meaning of certification of an intrinsically safe system, the process that the manufacturer must follow to obtain certification and the requirements and procedures that must be adhered to in order to achieve the required level of safety when installing and using the equipment. This paper presents the fundamental aspects of intrinsic safety certification with respect to fluid level instruments used in analyzing the performance of wells during drilling, production and workover operations.

Introduction

Echometer Company has always strived to provide the safest possible equipment for data acquisition and analysis of well systems performance. For over forty years, standard fluid level measuring equipment has been used worldwide without any instances of malfunctions that could have resulted in a hazardous situation. Continuing this tradition and in response to the recent development of international safety guidelines and requirements, a line of instruments have been developed that, when properly installed and used as directed, are certified to be safe for undertaking measurements in areas where explosive atmospheres are present (please see definitions at end of document). Figures 1, 2, 3 and 4 show the respective instruments.

The purpose of this paper is to give an overview, to oilfield personnel, of the certification process and the requirements for application of instruments for use in hazardous areas.

Hazardous Locations in the Oilfield

High pressure, high temperature and combustible gases are associated with oil and gas production operations. This implies that extreme care must be exercised whenever working in a hydrocarbon production area and especially whenever connecting or installing measurement equipment to wells. Certain concentrations of combustible gases in air constitute explosive mixtures that can be ignited by electrical sparks or the development of high temperatures.

Ignition and Explosions

An explosion requires the proper environment in order to exist. By eliminating those conditions an explosion is not possible. Three ingredients are necessary for an explosion:

- Fuel
- Oxidizer and
- Ignition source

All three components must be present in the correct proportions for ignition to occur. Once ignition occurs, if the conditions are right, a combustion wave can grow from the ignition. An explosion is any uncontrolled combustion wave. If the initial spark is not large enough, (i.e. not enough energy), the combustion zone will not have enough energy to self propagate. It will just collapse upon itself, and fizzle out. This means a small spark can occur in a potentially explosive air/gas mixture, with no danger of an explosion. The maximum amount of energy of this “safe” spark varies with the specific air/gas mixture present.

Area Classification

Hazardous materials (such as gas or dust) are grouped in CLASSES by their generic type as follows:

- Class I - Flammable Gases or Vapors.
- Class II - Combustible Dusts.
- Class III - Fibers or Flyings (particles normally suspended in air).

In Oil and Gas operations the most common hazardous materials correspond to **Class I** and are grouped according to their level of explosion hazard. The following groups are listed in order of the most to the least easily ignited.

- Group A - Acetylene (has a tendency to form copper acetylides which are easily ignited by friction).
- Group B - Hydrogen, Hydrogen Mixtures.
- Group C - Ethylene, most Ethers, some Aldehydes.
- Group D - Alkanes (Butane, Ethane, Methane, Octane, Propane), Hydrocarbon Mixtures (Diesel Oil, Kerosene, Petroleum, Gasoline), Alcohols, Ketones, Esters, Amines, Alkenes, Benzenoids.

Hazardous locations are classified by DIVISION according to the probability that an explosive concentration of hazardous material may be present.

- Division 1 - defines locations where there lies a high probability that an explosive concentration is present during normal operation. To be classified Division 1, there has to be a minimum of 100 hours/year, or 1% probability that an explosive material is present. In Europe, Division 1 is subdivided into Zone 0 and Zone 1. Zone 0 has the highest probability of an explosive concentration being present (greater than 10% probability).

- Division 2 - defines locations where there lies a low probability that an explosive mixture is present during normal operation (10 hours/year, or 0.1% of the time).

API Classification of Drilling and Production Facilities

The purpose of the API RP 500 recommended practice is to provide guidelines for classifying locations Class I, Division 1 and Class I, Division 2 at petroleum facilities for the selection and installation of electrical equipment following basic definitions given in the 1996 edition of NFPA 70, the National Electrical Code (NEC)

Section 10 of RP 500 defines the area classification for locations surrounding oil and gas drilling and workover rigs and production facilities on land and on marine fixed (bottom-supported) platforms where flammable petroleum gas and volatile liquids are produced, processed, stored, transferred, or otherwise handled prior to entering the transportation facilities.

Production facilities considered for classification by this section that impact measurements using Acoustic fluid Level equipment include the following:

Producing oil and gas wells

1. Flowing wells
2. Artificially lifted wells
 - a. Beam pumping wells
 - b. Mechanically driven, rotating, subsurface pumps
 - c. Electric submersible pumping wells
 - d. Hydraulic subsurface pumping wells
 - e. Gas lift wells
 - f. Plunger lift wells

The figures 5, 6 and 7 are examples of API classification of the areas surrounding producing wells. Figure 5 shows the areas for a rod pumping well, note that there are two zones indicated: a Division 1 zone in the sump, where hydrocarbon gases heavier than air may accumulate and a Division 2 zone surrounding the tree, stuffing box and a portion of the flowline. The lower part of this zone extends up to about 15 feet from the centerline of the polished rod and for added safety the measuring equipment must be supplied with 25 ft cables so that the electronic unit may be easily located away from the Division 2 zone.

The extent of the Division 1 and 2 areas for a well producing by Electrical Submersible Pumping are shown in Figure 6.

Drilling areas considered for classification by the RP 500 section and that impact measurements using acoustic fluid level equipment include the following:

- Rig floor and substructure area
- Blowout preventer (BOP)

Figure 7 shows a schematic diagram of these areas.

Note that typically the Division 1 area encompasses all areas where there is poor ventilation that increases the probability of hydrocarbon gas accumulation.

The areas removed from the boundary of the Division 2 areas are considered to be unclassified. The acoustic fluid level equipment that has been certified for use in explosive atmospheres consists of an electronic data acquisition and/or recording instrument that is connected by cable to a sensing instrument. As will be discussed in detail later, it is important to note that only the sensing element can be located in the Division 1 area, while the associated electronic package has to be located in an unclassified (safe) area.

This means that in the case of a pumping well, the instrumentation package has to be located at least 15 feet away from the well. In the case of an offshore platform, the instrument package has to be located in a safe area, for example in a positive pressure instrumentation room, which could be several hundred feet from the wellhead deck.

Explosion Prevention Methods

One of the methods used to prevent explosions in oilfield hazardous areas is to remove the ignition source since the fuel (gas) and oxygen (air) cannot be eliminated. For electrical instrumentation there are several methods to achieve the elimination of the ignition source:

- Explosion-Proof Enclosures
- Purging or Pressurization
- Encapsulation
- Oil Immersion or Powder Filling
- Intrinsic Safety

Explosion Proof Enclosures

The use of explosion-proof enclosures is a method which allows ignition to occur, but prevents any significant damaging results from the ignition. The enclosure contains the explosion so that it does not spread to the surroundings and cause damage to the plant and the personnel. Explosion-proof enclosures are designed to resist the excess pressure created by an internal explosion.

Purging or Pressurization

Purging prevents explosions by maintaining a protective inert gas within the enclosure at a pressure that is greater than the external atmosphere. Pressure may be preserved with or without a continuous flow of the inert gas.

Encapsulation

The encapsulation method encloses the hazardous circuit with a resin potting material that prevents accidental shorting of electrical components. If a spark does occur, it can not escape through the potting material into the hazardous environment.

Oil Immersion or Powder Filling

Oil Immersion – the equipment is immersed in oil. A spark can not pass through the oil covering to ignite the surrounding atmosphere. This method is sometimes used for large electrical apparatus such as transformers. The electrical apparatus may even have moving parts since the oil will not impede the movement.

Powder Filling - The enclosure containing electronics is filled with quartz powder. The level and granulometry of the powder is specified by an approval agency. A spark can not pass through the quartz powder and ignite the surrounding atmosphere. No moving parts are possible.

Intrinsic Safety

Intrinsic Safety (I.S.) removes the ignition source from the ignition triangle. The official definition is as follows: Intrinsically safe equipment and wiring shall not be capable of releasing sufficient electrical or thermal energy under normal or abnormal conditions to cause ignition of a specific atmospheric mixture in its most easily ignited concentration.

This method has the advantage of being relatively simple to implement, it does not require maintenance and is low cost per installation. It requires that the instrument be designed to meet the specifications and be tested by an authorized and recognized agency before it can be certified that it meets the safety regulations. Testing and certification is an expensive and time consuming process, but once certification has been obtained the manufacturer has only to build the equipment as specified by the certifying agency with the appropriate markings affixed to identify its level of safety.

Requirements to make a product Intrinsically Safe

Acoustic fluid level instrumentation consists of one or more field devices that are connected to the well and a data acquisition or recording instrument. To make this system intrinsically safe it is necessary to modify both the field devices and the instrument to eliminate the possibility of ignition of the explosive gases.

The field devices used in any hazardous area must be one of two types:

Simple Apparatus

A simple apparatus is a field device which meets the following requirements:

- Device does not store more than 1.2 Volts or 20 micro Joules.
- Device does not draw more than 100 mAmps.
- Device does not dissipate more than 25 mWatts.

Some examples of simple apparatus include: thermocouples, RTD's, switches and LED's. The pressure transducer used in acoustic liquid level surveys and the dynamometer load cell transducers generally consist only of resistive components and qualify as "simple apparatus".

Intrinsically Safe Certified Apparatus

Any device which does not fall into the category of simple apparatus must be certified that it is intrinsically safe. This includes transmitters, current to pressure converters, solenoid valves, piezoelectric microphones et.al. Certification must come from an organization such as CSA, or KEMA that is qualified to test the equipment to verify that under normal operating conditions and under conditions of faulty operation there is not sufficient energy delivered to the hazardous area to be able to cause ignition.

Figure 8 is one of the many graphs, which an intrinsic safety approval agency uses when certifying a field device for use in a particular hazardous area. These are actual ignition graphs for the various gases. They represent the amount of electrical energy required to cause the combustion of an air/gas mixture at its most easily ignited concentration. The area under the curves represents energy, which is too small to cause an explosion. This particular figure, used here as an example, applies to resistive circuits only and shows the combination of current and voltage that will ignite air/gas mixtures for groups A, B, C and D. When designing intrinsically safe products, a design safety factor of 1.5 is applied to the ignition current allowed.

The manufacturer must design the circuit to meet this requirement, and the analysis must be presented to the certifying authority at the time of the submittal for investigation. Currents and voltages should be computed under normal conditions and fault conditions. The values obtained should be compared to those permitted. In more complex circuits that include capacitors and inductances, the voltages and currents are computed at capacitors and inductors after single faults and for the worst-case combinations of two components or wiring failures, in addition to opening, shorting, or grounding of external wiring.

Intrinsic Safety Barrier

When an intrinsically safe field device has to be connected to an instrument that is not certified for use in a hazardous area, it is necessary to interpose a circuit to limit the energy that might be transmitted from the instrument to the hazardous area. Such a circuit is called an "Intrinsic Safety Barrier" This concept is shown schematically in the following figure 9. The intrinsic safety barrier is an electronic circuit used to connect a non-certified instrument equipment in a safe area to a certified or simple field device in a hazardous area.

A barrier **cannot** be used to make an uncertified device safe in a hazardous area. If a field device is uncertified, it could have internal energy storing components that in the case of a fault, may cause a spark, which in turn may start the combustion process.

The barrier only prevents the non-certified device in the safe area from transmitting dangerous energy to the hazardous area. In summary, the barrier is an energy limiting device placed on the electrical wires between the safe and hazardous areas.

For the Echometer systems, the field device (Compact gas gun or 5000 psi gas gun) have been certified for installation in a Class 1 Division 1, Group A, B, C &D, T4 area, while the pressure transducer is classified as a simple device. The Well Analyzer or the Model M instruments have been modified by internally adding the energy limiting circuits that act as the safety barrier. These facts are attested by the markings that are inscribed on the instruments and the end devices. The combined elements are intrinsically safe provided that they are connected and used as shown in the corresponding installation drawings that accompany the certification documents.

Certification

Intrinsically safe products and systems are certified or approved as safe by various agencies. These same agencies also approve explosion-proof devices, enclosures and accessories. The approval agency does all the safety analysis for the end user. The certification agencies in the U.S.A. are Underwriters Laboratory (UL) and Factory Mutual Research Corporation (FM or FMRC). Typically, FM does most of the intrinsically safe approvals. The design standard, which both FM and UL design their approval processes to meet, is ANSI/UL 913 (formerly NFPA 493). The installation standard is ANSI/ISA RP 12.6, "Installation of Intrinsically Safe Instrumentation Systems in Class I Hazardous Locations." This documentation should be used for guidance on intrinsically safe installations.

In Canada, Intrinsically Safe product approvals are obtained through the Canadian Standard Association (CSA). This group develops the standard and also certifies devices to the standard. CSA certification is accepted and recognized in the US and in most foreign countries.

The European Union (EU) has developed certification standards in response to the European Parliament directive : "DIRECTIVE 94/9/EC OF THE EUROPEAN PARLIAMENT AND THE COUNCIL OF 23 MARCH 1994 ON THE APPROXIMATION OF THE LAWS OF THE MEMBER STATES CONCERNING EQUIPMENT AND PROTECTIVE SYSTEMS INTENDED FOR USE IN POTENTIALLY EXPLOSIVE ATMOSPHERES"

The EU standards are more stringent than the US or Canadian standards and are commonly referred to as the ATEX standards. Certification is issued by special organizations defined as "notified bodies". EU certification includes the requirement that the manufacturer shall operate an approved quality system for production, final equipment inspection and testing and shall be subject to monitoring by a quality inspector.

Procedure

The general procedure to be followed by a manufacturer to obtain certification for a specific system may be outlined as follows:

Supply the following information to the certifying agency through a designated contact person:

- A marketing brochure or data sheet describing the product (what it is, what it does, and what it looks like)
- Photographs of the product
- Operating manual
- A list of all components or materials used in the product, including the manufacturers' names, model or catalogue designations, electrical ratings (if applicable), and certifying agency file numbers (if applicable)
- Indication of any other approvals either already received or being pursued.
- Any alternate materials or components that might be used in manufacturing
- Schematic and/or wiring diagrams, if this is an electrical or electronic product
- The model or catalogue numbers to be covered by this certification, and the similarities and differences between models
- The full name and address of all facilities where the product will be assembled, and a contact person for each facility.

The certifying agency will respond to the submission with a reference number, fixed fee, schedule, sampling requirements, and the name of the staff member assigned to the project (the Project Holder).

The next step involves providing a sample of the product to be certified and any test data if available. If the product or some components have already been tested by an accredited testing organization, the report containing those test results should be submitted.

Once the product has been tested, the agency will issue a findings letter. The Findings letter tells the results of the test and what to do next to obtain certification. This letter may ask for response to specific items, or to alter the product to meet certain requirements. If the product is ready for certification, the Findings letter will include a proposed Certification Record.

If the product meets all the requirements, the agency will issue a Certification Report and Certificate of Compliance. The agency will also detail any requirements to be met as far as installation of the product, specific instructions to be included in operating manuals, specific installation drawings and specific markings to be placed on the product.

Markings

After certification is obtained, all equipment and protective systems must be marked legibly and indelibly with the following minimum particulars:

- Name and address of the manufacturer;
- CE marking
- Designation of series or type;
- Serial number, if any;
- Year of construction;
- The specific marking of explosion protection followed by the symbol of the equipment-group and category;
- For equipment-group II, the letter G' (concerning explosive atmospheres caused by gases, vapors or mists)

Furthermore, where necessary, they must also be marked with all information essential to their safe use. Figure 10 illustrates and explains the meaning of the required markings for North America and Figure 11 illustrates and explains the meaning of the required markings for Europe:

Field Use of Certified Equipment

All equipment and protective systems must be accompanied by instructions, including at least the following particulars:

- A summary of the information with which the equipment or protective system is marked, together with any appropriate additional information to facilitate maintenance (e.g. address of the importer, repairer, etc.);
- Instructions for safe putting into service, use, assembling and dismantling, maintenance (servicing and emergency repair), installation, adjustment; where necessary, an indication of the danger areas in front of pressure-relief devices; where necessary, training instructions.
- Electrical and pressure parameters, maximum surface temperatures and other limit values;
- Where necessary, special conditions of use, including particulars of possible misuse which experience has shown might occur;
- Where necessary, the essential characteristics of tools which may be fitted to the equipment or protective system.

Installation Drawings

The equipment must be accompanied by an installation drawing that shows clearly how the field element and the electronic instrument should be installed, their location and pertinent mode of operation. Figure 12 is an example of the installation of the acoustic fluid level systems. It shows that the electronic module must be installed in a SAFE area and also that neither the computer battery nor the electronic instrument internal battery can be charged from any external power source while the equipment is in use.

Certificates

After the certification process has been completed and the instruments have been approved for use in hazardous areas, the certifying authorities issue certificates of compliance. Besides the manufacturer of the equipment, the certificates are available to the public through the agencies web sites, for example the certification record from KEMA at the following URL:

www.KEMA.com

or from the CSA data base of certified products at the following URL:

<http://www.csa-international.org/product/> as shown in Figure 13.

Definitions

1- Explosive atmospheres - Mixture with air, under atmospheric conditions, of flammable substances in the form of gases, vapors, mists or dusts in which, after ignition has occurred, combustion spreads to the entire unburned mixture.

2- Intrinsically safe - Intrinsically safe is an attribute applied to electrical equipment that is designated for use in explosion-prone areas. It is applied to equipment in which any spark or source of heat that may occur in normal use, or under any conditions of fault likely to occur in practice; is incapable of causing an ignition of a methane-air mixture.
<http://www.labour.gov.sk.ca/safety/mine-rescue-manual/appendices/appendix-d.htm#I>

3- Unclassified Location (non-hazardous location): A location not classified as Division 1 or Division 2. (API RP500)

4- Hazardous (classified) location: A location where fire or explosion hazards may exist due to flammable gases or vapors, flammable liquids, combustible dust, or ignitable fibers or flyings. (API RP500)

References

API RECOMMENDED PRACTICE 500, Recommended Practice for Classification of Locations for Electrical Installations at Petroleum Facilities Classified as Class I, Division 1 and Division 2

SECOND EDITION, NOVEMBER 1997, Reaffirmed 11,2002

KEMA

Founded in 1927, KEMA is a commercial enterprise, specializing in high-grade technical consultancy, inspection, testing and certification. KEMA is a Notified Body for the 94/9/EC Directive, the ATEX Directive, and as an independent party can establish whether products comply with this directive. www.KEMA.com

CSA

The Canadian Standards Association is a not-for-profit membership-based association serving business, industry, government and consumers in Canada and the global marketplace. As a Standards Development Organization (SDO) it is accredited by the Standards Council of Canada and works in Canada and around the world to develop standards that address public safety and health. CSA can test and certify products to Canadian and U.S. standards and issue the CSA Mark for qualified products.

FM

Factory Mutual, FM Approvals is an ATEX notified body (No. 1725) within Europe and can undertake the assessment, testing and certification of products and manufacturing facility against the ATEX directive.

<http://www.fmglobal.com/approvals/>

Figures

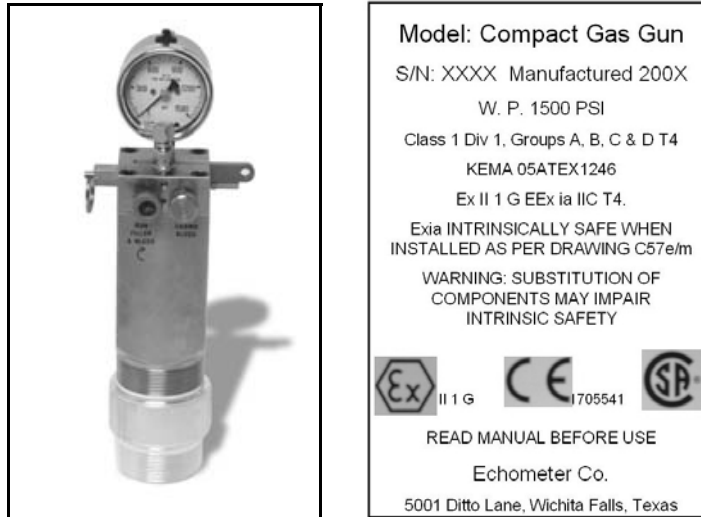

Figure 1 - Compact Gas Gun modified (as shown by the engraving) with special microphone for use in hazardous areas:

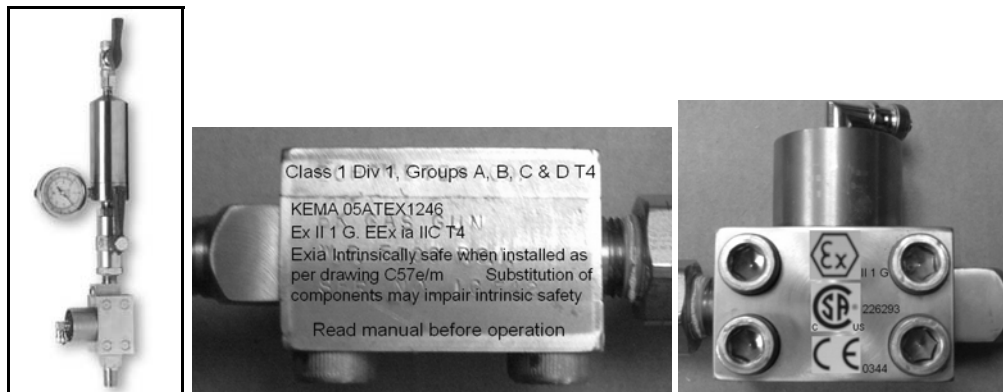

Figure 2 - 5000 psi Gas Gun modified (as shown by the engraving) with special microphone for use in hazardous areas:



Figure 3 - Model M Acoustic Fluid Level Instrument that has been modified, as shown by the engraving, to include safety circuits to limit electrical energy output in the event of a component malfunction and using the manual gas guns listed above with the model E installed in a safe area.

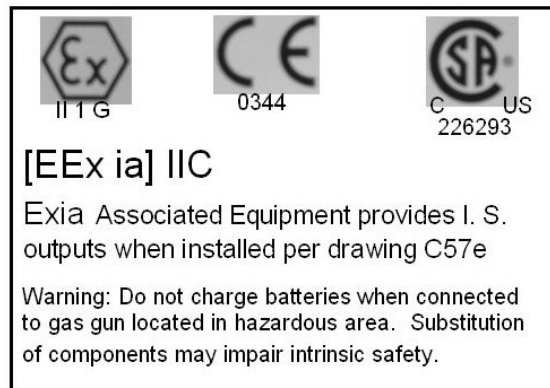

Figure 4 - Model E Well Analyzer that has been modified, as shown by the engravings, to include safety circuits to limit electrical energy output in the event of a component malfunction and using the manual gas guns listed above with the model E installed in a safe area.

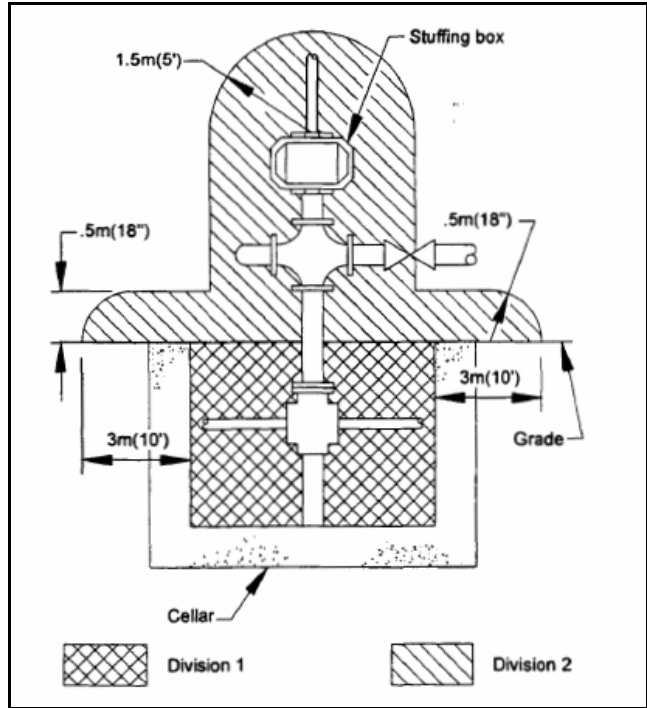

Figure 5 – Classification of hazardous zones for a rod pumped well according to API-RP500

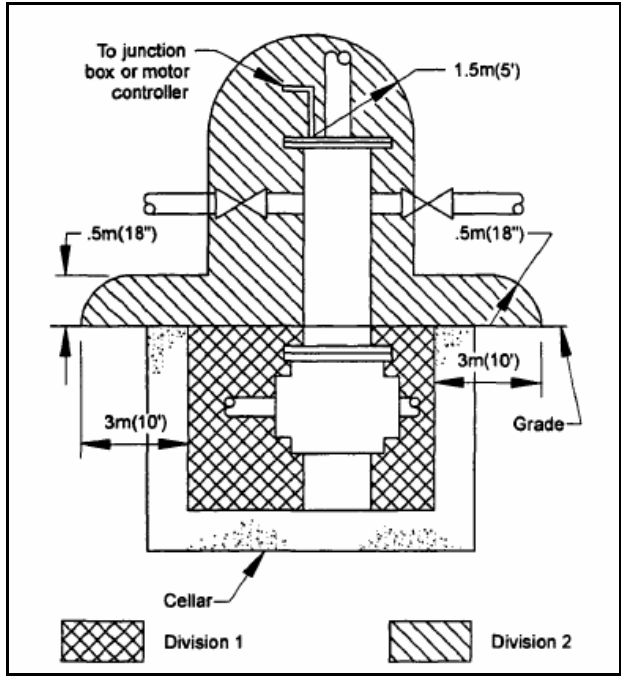

Figure 6 - Classification of hazardous zones for an electrical submersible well according to API RP 500

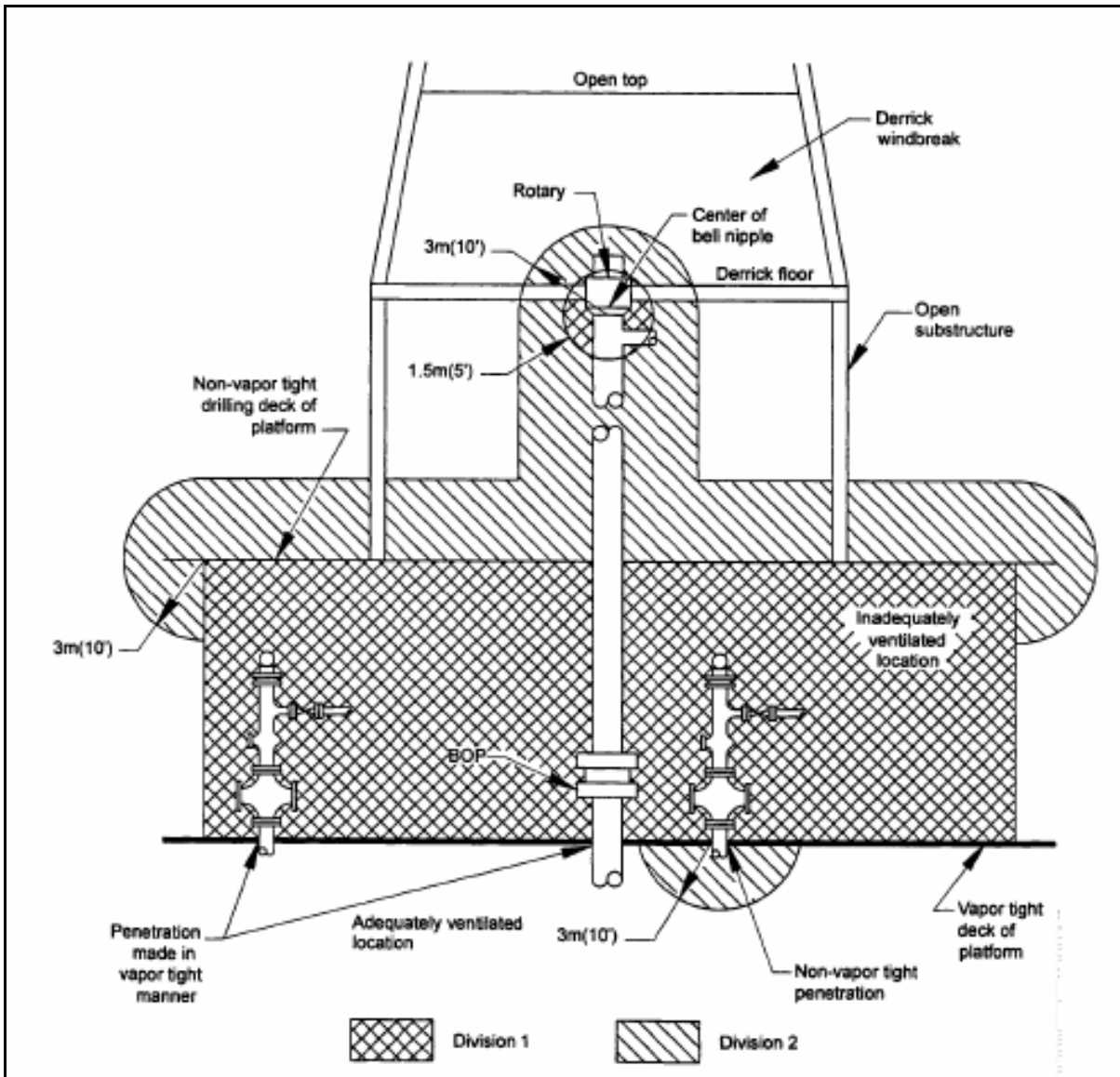

Figure 7 - Drilling areas considered for classification by the RP 500 section and that impact

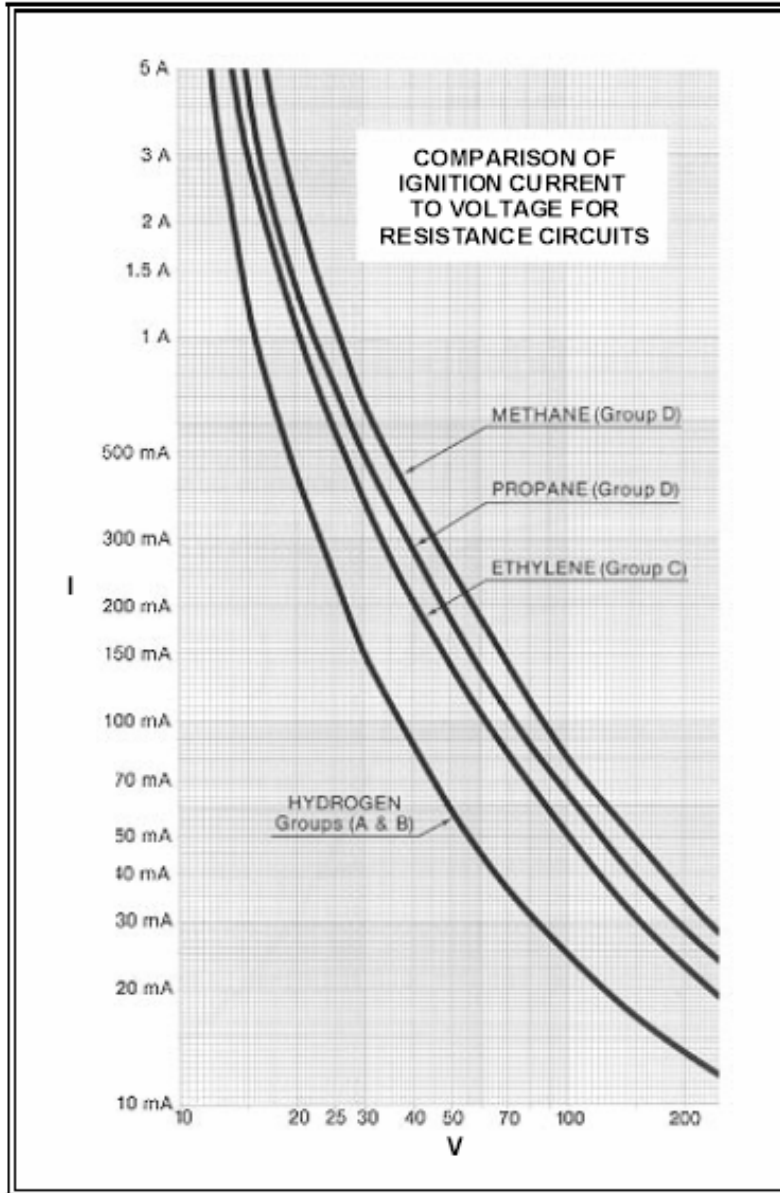

Figure 8 – Ignition current and voltage limits for resistive circuits.

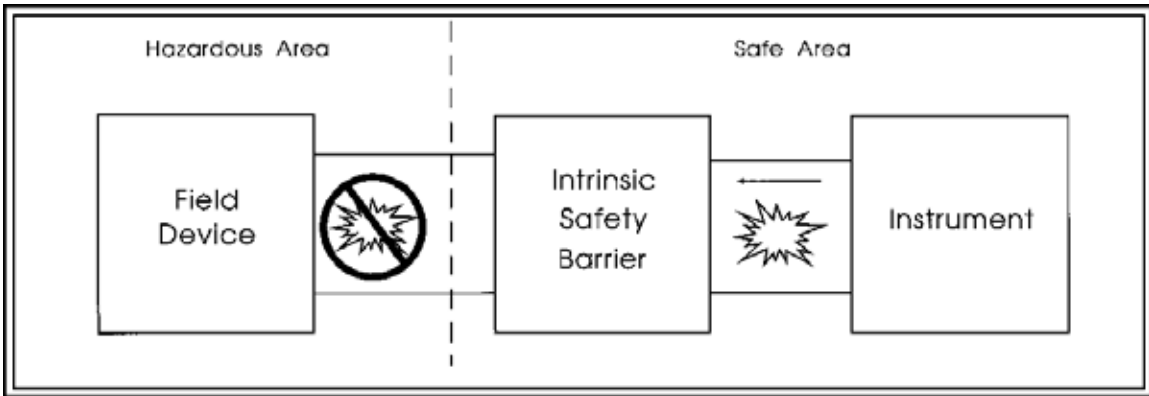

Figure 9 - The intrinsic safety barrier is used to connect a non-certified instrument equipment in a safe area to a certified or simple field device in a hazardous area.

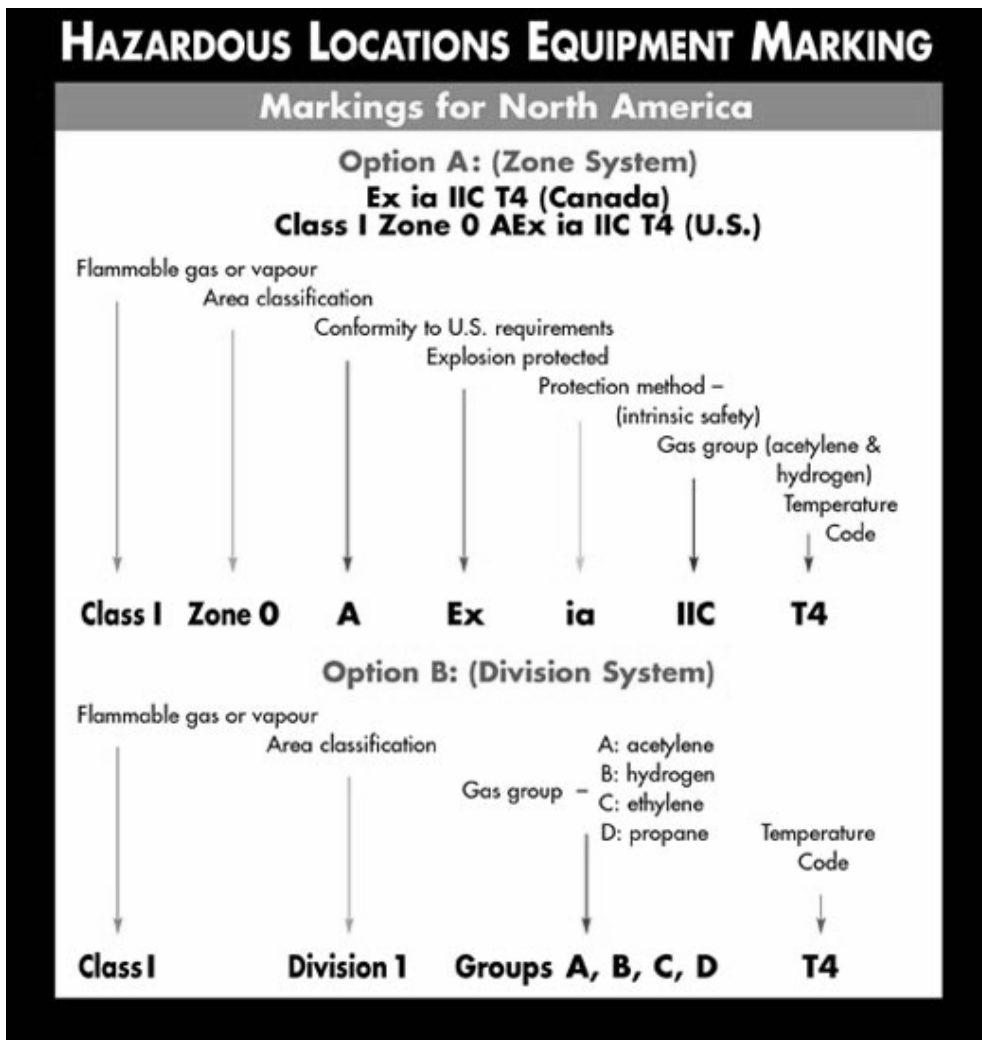

Figure 10 – Markings required to be placed on certified equipment by North American standards.

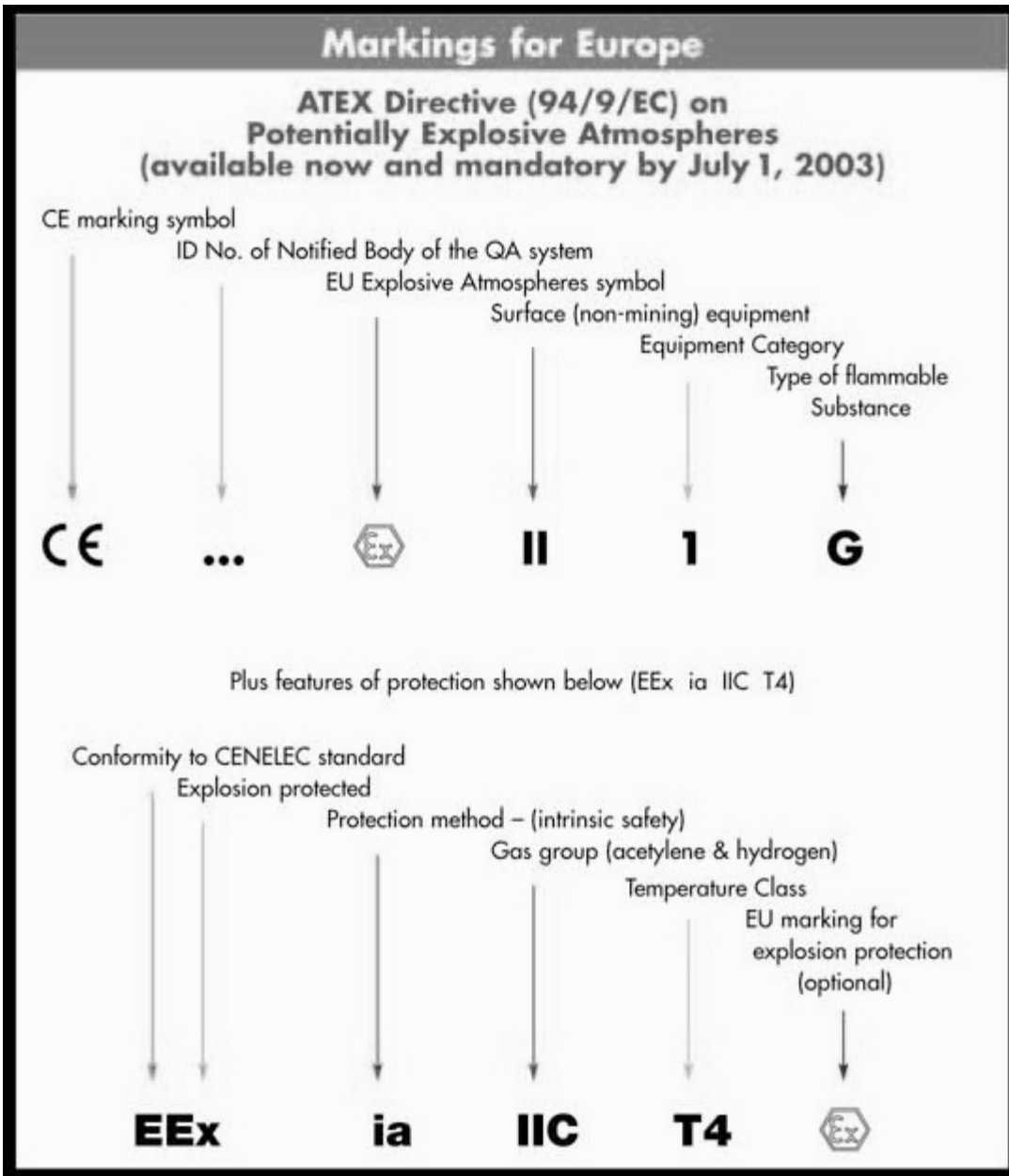

Figure 11 - Markings required to be placed on certified equipment by European standards.

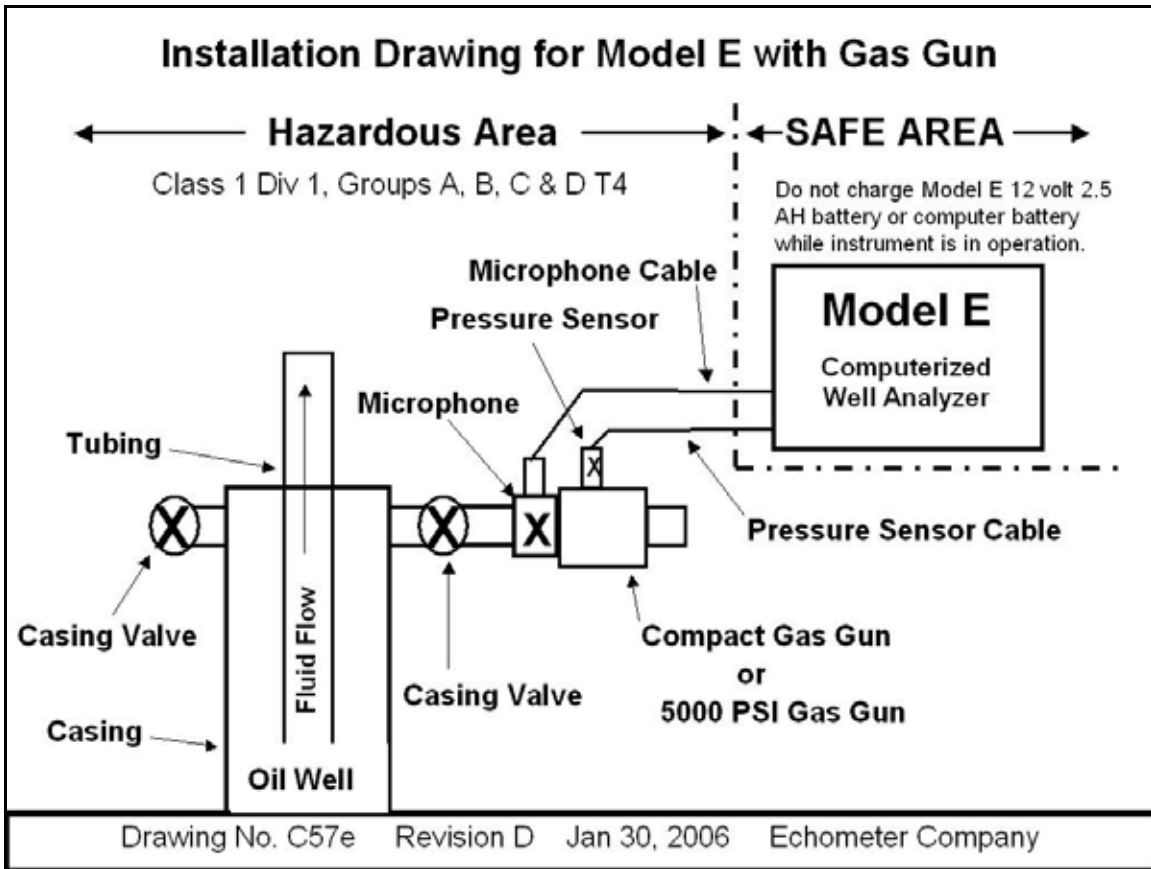

Figure 12 – Installation drawing required to be supplied to the user of the certified equipment.

Certification Record		
CUSTOMER	CLASS	FILE
Echometer Company 5001 Ditto Lane, Wichita Falls TX 76302 USA	2258-03 PROCESS CONTROL EQUIPMENT - Intrinsicly Safe and Non-Incendive Systems - For Hazardous Locations Refer to Class Description for program details	226293
Class I, Division 1, Division 2, Groups A, B, C and D		
<ul style="list-style-type: none"> • Acoustic Level Instruments; consisting of the following <ul style="list-style-type: none"> - Model M, Acoustic Level Instrument for use with referenced Gas Gun, battery powered, rated 12V - 2.5AHr, for use in an Ordinary Location. - The Well Analyzer, Model E, Acoustic Level Instrument for use with referenced Gas Gun, battery powered, rated 12V - 2.5AHr, for use in an Ordinary Location. - Gas Gun with integral Intrinsicly Safe piezo microphones, for use in Class I, Division 1 and 2, Groups A, B, C and D; when connected to the Model M Acoustic Field Fluid Level Instrument per installation drawing C57m or the Well analyzer (Model E) per installation drawing C57e; Temperature Code: T4 - "Compact Gas Gun", rated for a 1500psi application, - "5000psi Gas Gun", rated for 5000psi application 		

Figure 13 – Example of certification record obtained from the CSA database.