

PREVENTIVE MAINTENANCE FOR REMOTE FIRE GAS GUN

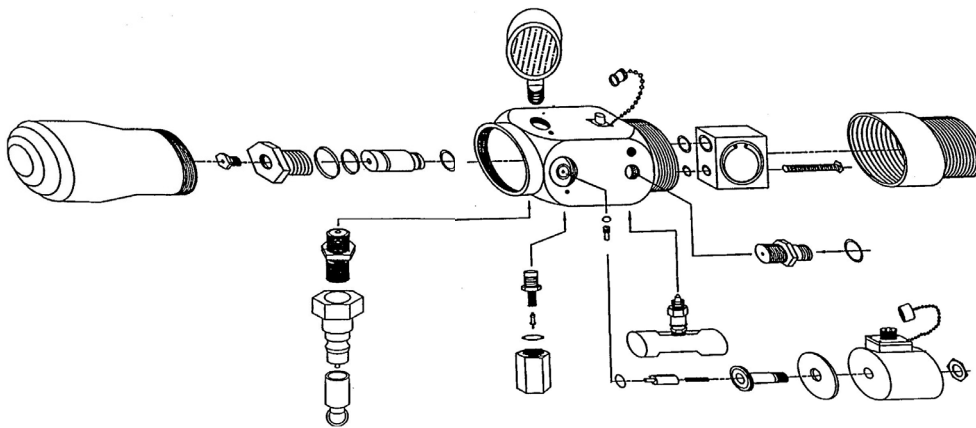

Visit WWW.ECHOMETER.COM for additional information.



See Attached Dwg. 1 and Dwg. 2 for Part Numbers and Drawing Details

1. When the remote fire gas gun is placed onto the well, charge the gas gun volume chamber to a pressure in excess of well pressure before opening the casing valve. The remote fire gas gun utilizes a solenoid with a small dart valve and a small orifice. The dart valve releases gas from behind a 1/2 inch moveable piston that allows gas from the gas gun volume chamber to flow into the well. These small moving parts will become clogged and inoperable if sand and debris are blown from the well into the gas gun volume chamber. Debris and sand will prevent the

Echometer Company
Phone: (940) 767-4334

5001 Ditto Lane
Fax: (940) 723-7507

Wichita Falls, TX 76302 U.S.A.
E-Mail: info@echometer.com

PREVENTIVE MAINTENANCE FOR REMOTE FIRE GAS GUN

dart valve from properly sealing, and gas will bleed continuously from the gas gun volume chamber into the well. This requires that the gas gun be disassembled, cleaned and reassembled. The gas gun volume chamber should be charged to a pressure in excess of well pressure with CO₂ or nitrogen gas to close the gas valve and prevent well gasses and debris from the well being blown into the gas gun volume chamber. When the remote fire gas gun is placed onto the well, charge the gas gun volume chamber to a pressure in excess of well pressure before opening the casing valve. This will close the gas valve and prevent debris from being blown into the gas gun mechanism. Also, most well gases contain water vapor. This water vapor will be blown into the gas gun volume chamber if the gas valve is not closed by pressure in the volume chamber in excess of the well pressure. This water will cause corrosion and rust that will further contaminate the mechanism

2. **Protect the remote fire gas gun housing threads from corrosion.** The threads on the gas gun can become damaged or corroded. Protect the threads with a light coating of grease or oil and place a plastic cap on the threads. The pressure rating of 2000 psi should be reduced if corrosion or worn threads exists. A corrosion protective coated steel 2" 11 ½ V male to female adapter (mic protector) is available for protecting the gas gun threads and microphone. The mic protector is supplied with new remote fire gas guns. The mic protector should be installed and replaced as needed.

3. **Clean the dart valve, if gas is constantly leaking from the hole underneath the pressure gage.** If pressure is constantly leaking out the small pressure relief hole underneath the pressure gage, then probably the dart valve inside the solenoid assembly is not sealing, allowing pressure to leak out the pressure relief hole. The solution is to disassemble the solenoid and clean the dart valve assembly. Use the spanner wrench to remove the nut and use your hand to remove the solenoid coil housing. Remove the flux washer that fits on the bottom of coil housing and again use the spanner wrench to unscrew the plunger assembly from the housing. When removing the plunger housing be careful to not drop the plunger spring or dart valve and plunger. The dart valve is the little plastic needle inside of the plunger. You should visually examine the dart valve tip for any debris. Any debris can prevent the dart valve from making a gas tight seal in the dart valve seat; just a grain of sand, a small metal shaving, or other debris can get between the dart valve and seat and can prevent an airtight seal. The debris will allow pressurized gas to leak past the dart valve and out of the vent. To clean the dart valve wipe the tip with a soft clean cloth or in the field your finger will normally work ok. Once the dart valve is clean, then reassemble the solenoid assembly.

If the tip of the dart valve tip is damaged, then it must be replaced. The dart valve can be removed from the plunger. Then replace the dart valve with new valve and reassemble the solenoid assembly.

After cleaning the dart valve and if the remote fire gas gun still leaks out the small pressure relief hole underneath the pressure gage, then the dart valve seat should

PREVENTIVE MAINTENANCE FOR REMOTE FIRE GAS GUN

be inspected. The dart valve seat sits just underneath the dart valve plunger assembly and is held in place with an O-ring. The seat can be removed and there could be debris lodged inside the seat. Spray contact cleaner through the dart valve hole and through the two slots on either side of dart valve seat. The spray will purge out all debris and clean the hole. The O-ring on the dart valve seat should be free of cuts and abrasions. After the seat is inspected, then replace and lubricate the O-ring on the dart valve seat. Then reassemble the solenoid assembly and tighten with a wrench.

4. **Replace the O-ring on the gas valve, if gas is leaks from the bottom end of gun.** The symptom of gas pressure bleeding past the gas valve and leaking out the bottom end of gun, leaking into the well, is shown by the pressure gauge not building or holding a positive pressure. Most likely the problem is caused by the smaller of the two O-rings (WG-1700) on the gas valve being cut. The cut in the O-ring is allowing gas pressure to flow past the O-ring and into the well. The solution to repair this problem is to remove the gas valve and replace the O-ring. To disassemble the remote fire gun: 1) remove the volume chamber to expose the orifice and the orifice housing, 2) remove the orifice housing with a 7/8 inch socket wrench, 3) use the repair kit's 6-32 machine screw to screw in the top of the gas valve, and 4) pull the gas valve from the housing. Inspect the small O-ring on the bottom side of the gas valve for cuts or mis-shape. The smaller of the two O-rings does most of the work and most of the sealing, because it fits in a hole in the bottom of the housing and seals off the chamber. The gas valve is continuously working up and down as the gun is fired, so the small O-ring takes a lot of wear and tear. When the gas valve is removed, then O-ring lubricant or bearing grease should be applied to the O-rings. The lubrication helps gas valve to slide more freely and lengthens the life the O-rings. Inspect the WG-1600 O-ring on the bottom side of the orifice housing and replace if the O-ring is cut or if it is worn. Failure of the WG-1600 O-ring can prevent the orifice from functioning properly, allowing gas pressure to bypass the orifice and leak underneath the orifice housing into the gas valve chamber. This type of leak prevents gas pressure from being bled off of the top side of the gas valve rapidly enough for the gun to fire properly.
5. **Clean the orifice and orifice housing if they become clogged.** The orifice has a 0.015" hole through its center and it is screwed into the orifice housing. The orifice or the orifice housing needs to be cleaned if clogged with debris that restricts the flow of gas pressure into the volume chamber. The orifice and orifice housing are cleaned by first removing them from the gun, then spraying WD 40 or a pressurized electrical contact cleaner through them. The orifice is removable and can be replaced with a new one, however the orifice is normally reliable and trouble free.
6. **Lubricate O-rings on the moving gas valve.** Put a little bit of lubricant inside the gun as well. Make sure the chamber inside the gun is clean where the gas valve actually operates. A build-up of gunk or debris inside the volume chamber can prevent that gas valve from moving freely and the gas valve has to move freely to work properly. Do not wait for long periods between maintenance of the gas valve.

PREVENTIVE MAINTENANCE FOR REMOTE FIRE GAS GUN

The remote fire gun should be taken apart, cleaned and re-lubricate the O-rings. Lack of proper maintenance will allow the O-rings to become dry and friction can actually stick that gas valve inside the gun. The O-rings have enough friction on them that if they become dry, then they can stick that gas valve and not allow the remote fire gun to cock. If excessive pressure is required to cock the remote fire gas gun, then the gas valve probably needs to be lubricated. If a pressure build-up test is to be performed on a well, then the recommended practice is to inspect both the dart valve and gas valve before the start of the test.

7. **Do not fill the gas gun with liquid CO₂.** Occasionally, the valve core filler bleed chamber valve can stick open and blow CO₂ gas out of the volume chamber into the atmosphere. The gas leakage is caused by the CO₂ freezing, as it is discharged into the gas gun volume chamber. Filling the gun with gas instead of liquid CO₂ can prevent freezing of the valve core. When any type of CO₂ cylinder is used, the top of the cylinder should be above the bottom of the cylinder so that gas at the top is discharged from the cylinder into the gun instead of liquid CO₂ from the bottom of the cylinder. If the gas gun is filled with the cylinder located directly above the gas gun, the liquid CO₂ in the cylinder can freeze as it enters the gas gun and cause the gas gun bleed valve to leak when the filler connector is removed from the gun connector.
8. **Keep debris out of the filler connector housing.** If debris in the valve core filler connector housing causes the gas gun to leak, lubricate the valve core with light oil. Remove the filler connector housing and add light oil directly onto the valve core. Install the filler connector housing and then refill and discharge the gas gun with CO₂ a few times. Firing the gun multiple times will remove the debris from the valve core. Be sure that the valve core is properly tightened while the filler connector housing is removed.
9. **Replace filler connector housing when small fill tube is damaged.** When the 7.5 ounce CO₂ bottle is used to fill the remote fire gas gun, occasionally, the 7.5 ounce CO₂ bottle will be forced from the filler connector housing due to the pressure in the CO₂ bottle forcing the filler connector's nozzle away from the filler connector housing. A worn or bent or flattened small fill tube in the filler connector housing prevents the CO₂ gas from being released into the gas gun volume chamber. The solution is to replace filler connector housing.
10. **The internal wire on the remote fire gas gun microphone BNC connector can be broken.** Pulling the microphone BNC connector too far from the housing will break the internal wire. If the coax cable becomes stuck to the microphone BNC connector do not try to jerk it loose. Be sure to use a 90-degree "L" electrical BNC connector with the remote fire gas gun to protect the BNC connector on the gas gun. When attaching and removing a cable to the BNC connector or to the 90-degree "L" electrical BNC connector, use care. These connections must be maintained clean at all times.

PREVENTIVE MAINTENANCE FOR REMOTE FIRE GAS GUN

11. **When switching the filler connector from an empty bottle to a full bottle, remove the filler connector from the empty bottle and wait 5 minutes for the swollen O-ring to reduce in size.** Generally, the filler connector on a 7.5-ounce bottle is removed when the bottle is empty and the filler connector is placed onto a full CO2 bottle in order to continue testing wells. When the filler connector is removed, the purple O-ring on the filler connector will swell. When the filler connector with the swollen O- ring is placed onto a 7.5 ounce CO2 bottle, the swollen O-ring is generally damaged when the filler connector is attached to the new bottle that causes the CO2 to leak from the bottle. When switching the filler connector from an empty 7.5 ounce CO2 bottle to a full 7.5 ounce CO2 bottle, remove the filler connector from the empty bottle and wait 5 minutes for the swollen O-ring to reduce in size. After it reduces to normal size, lubricate the O-ring with a few drops of oil and install onto the full 7.5-ounce CO2 bottle.
12. **The microphone cannot be repaired in the field, do not disassemble. If fluids enter the inside of the microphone, the microphone will be damaged.** Saltwater will cause immediate failure of the microphone if it is allowed to enter the inside of the microphone. Clean the lower threaded portion of the remote fire gas gun after each day's use with a mild cleaner such as soapy water, alcohol, WD 40 or a pressurized electrical contact cleaner which can be obtained from an electrical supply store. Then, coat the inside of the gas gun lower chamber with grease or a light coating of oil. If the microphone is removed from the remote fire gas gun, be sure to clean the lower portion of the remote fire gas gun thoroughly and also the microphone before attempting to reinstall the microphone into the lower chamber. If the microphone is removed from the remote fire gas gun always replace the O-ring with a new O-ring that fits over the electrical connection between the microphone and the remote fire gas gun. Be sure to lubricate the O-ring with an O-ring lubricant, grease or oil.
13. **When wells are chemically treated at the surface, the Echometer gas gun should be cleaned at the end of each day.** The gun and microphone are constructed from stainless steel and the microphone has mylar plastic coatings. Almost all hydrocarbon oils and water will not damage the microphone. Some wells are chemically treated at the surface for corrosion. High concentrations of some chemicals are corrosive and will cause corrosion to the stainless steel Echometer gas gun parts. If the wells to be acoustically tested are chemically treated at the surface, the Echometer gas gun should be cleaned at the end of each day because the chemical may be corrosive to gas gun parts. To clean the gas gun, first, pressurize the gas gun. Then use a hydrocarbon solvent, soapy water, alcohol or household cleaning agent to clean the portion of the gas gun that is exposed to well gases. Allow parts to drip dry or blow dry with compressed gas psi.

**Repair Personnel: Marvin Craft: Extension 20
Rusty Ham: Extension 19**

Echometer Company
Phone: (940) 767-4334

5001 Ditto Lane
Fax: (940) 723-7507

Wichita Falls, TX 76302 U.S.A.
E-Mail: info@echometer.com

PREVENTIVE MAINTENANCE FOR REMOTE FIRE GAS GUN

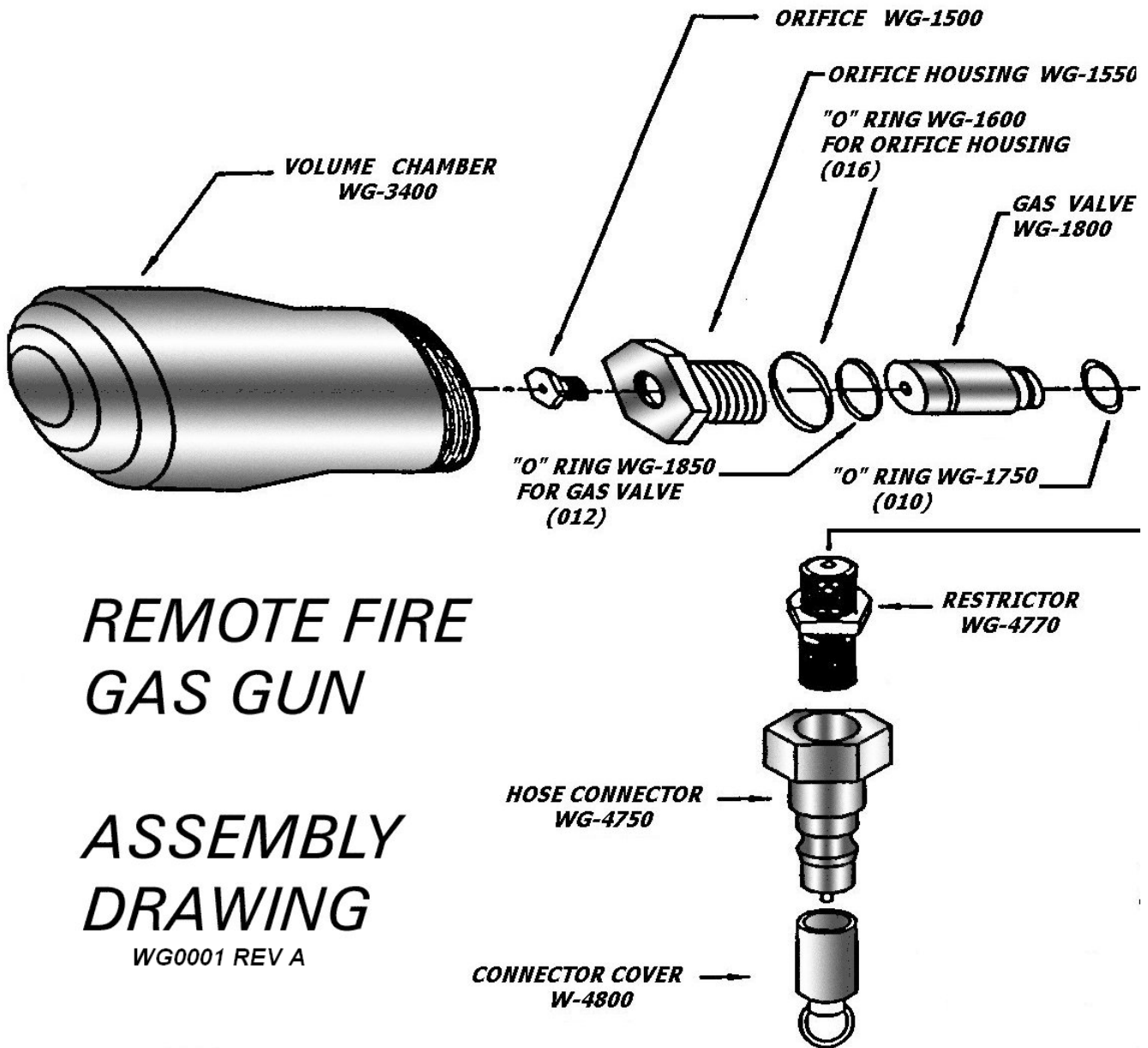

**REMOTE FIRE
GAS GUN**

**ASSEMBLY
DRAWING**

WG0001 REV A

PREVENTIVE MAINTENANCE FOR REMOTE FIRE GAS GUN

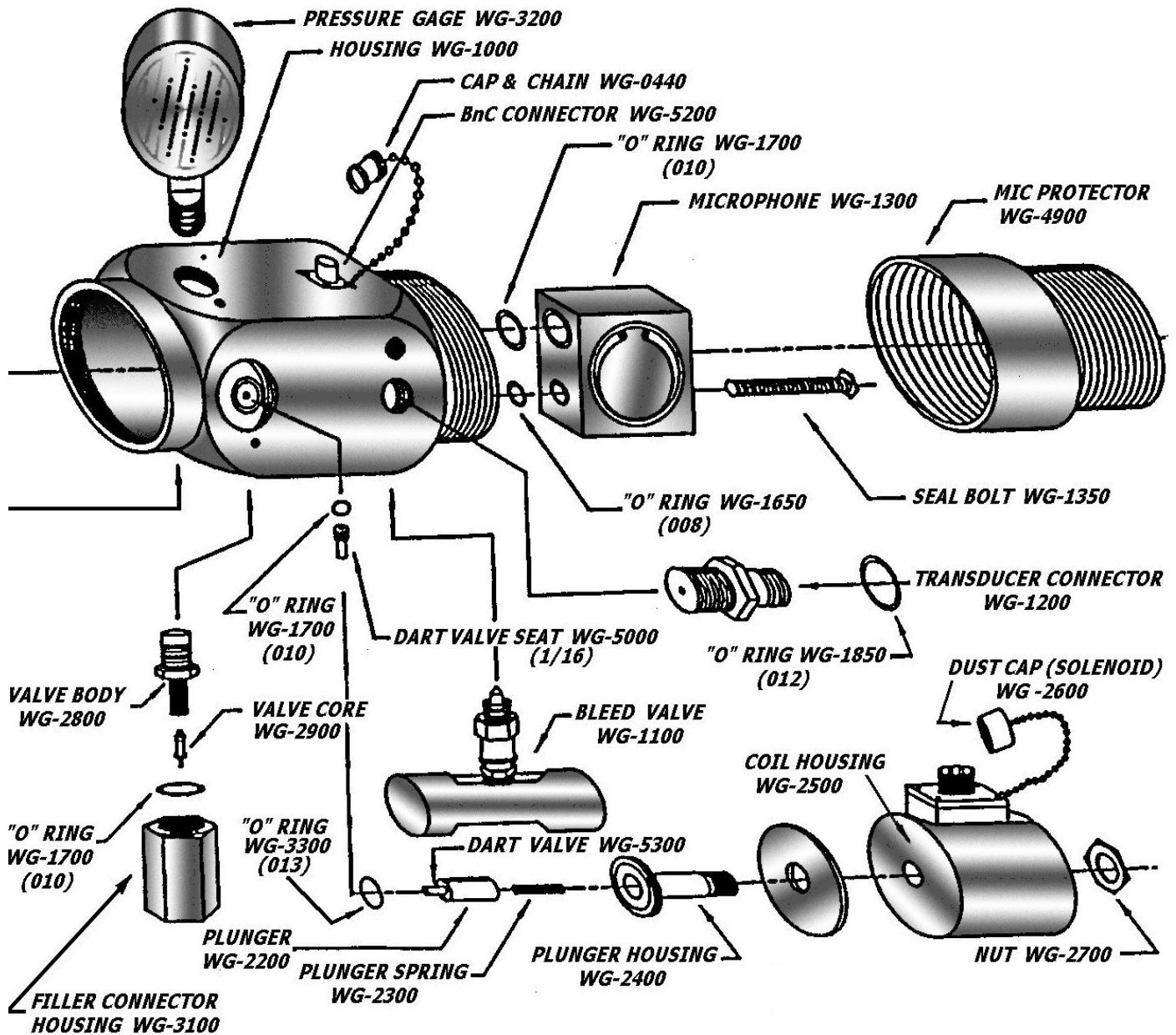

Echometer Company
Phone: (940) 767-4334

5001 Ditto Lane
Fax: (940) 723-7507

Wichita Falls, TX 76302 U.S.A.
E-Mail: info@echometer.com